

# PLE

- PLE applications 67
- PLE dimensions 68
- PLE types 69
- PLE sizes 71
- PLE parts 72
- PLE assembly 73
- PLE part numbers 76



closed + open

## PLE CHARACTERISTICS

The PLE with aluminum stays is available as **PLE** with plastic inserts or plastic slot profile, as **PLS** with foam slot profile or as **PLP** with plastic divider PZ.

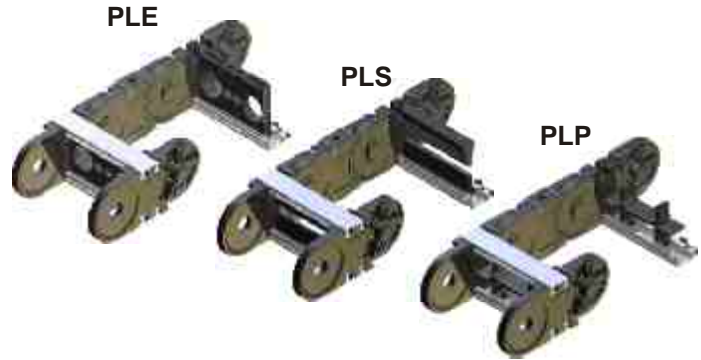

- positive stay locking
- both inside and outside radius can be opened
- simple to shorten or lengthen
- stepless stay length up to 1000 mm

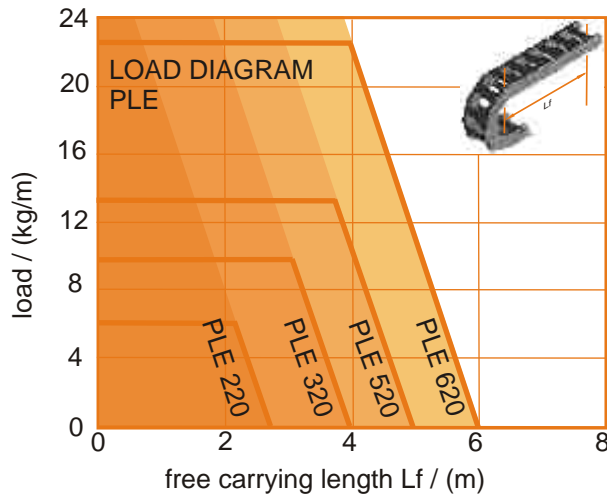

All ekd plastic energy chains are equipped with the **integrated connector**. Additional components for mounting the energy chain are not required.

## Travel

The maximum travel is determined by the arrangement and the additional weight (line weight). At normal arrangement the maximum travel is twice the free carrying length. Support rollers or similar constructive steps can increase this value.

In gliding arrangements travel distances up to 100 meters are possible.

Longer travel distances need further constructive steps, like SYSTEM MARATHON, which exceeds the travel distance nearly without limits.

## Travel speed

There are no limits for the travel speed in general. But in gliding applications specific influences have to be taken into account.

## Acceleration

In principle there are no restrictions for the acceleration. Limits can only be achieved at high tension forces caused by high additional weights.

## Temperature

The operating temperature is in between  $-20^{\circ}\text{C}$  and  $100^{\circ}\text{C}$ .

## Special versions

- |          |                        |
|----------|------------------------|
| ALLROUND | ... all movements      |
| ATEX     | ... EX-protection      |
| ESD      | ... antistatic         |
| V-0      | ... self extinguishing |

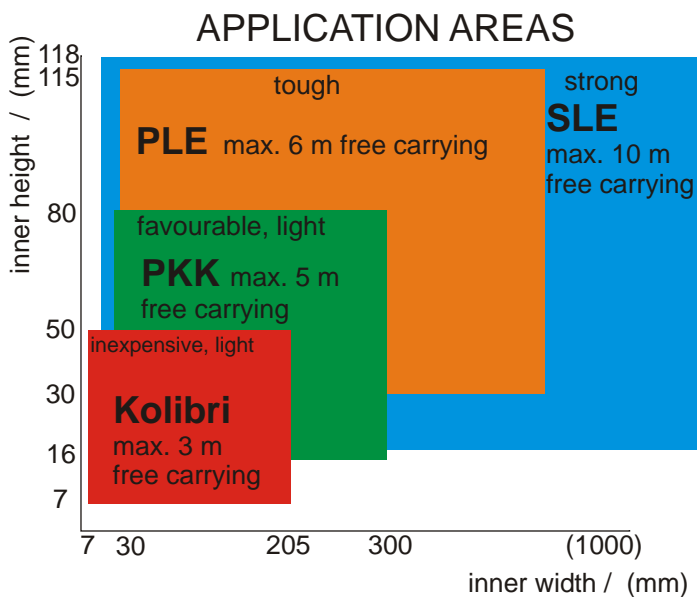



**Machine tools,  
Handling technology,  
Conveying and lifting equipment**



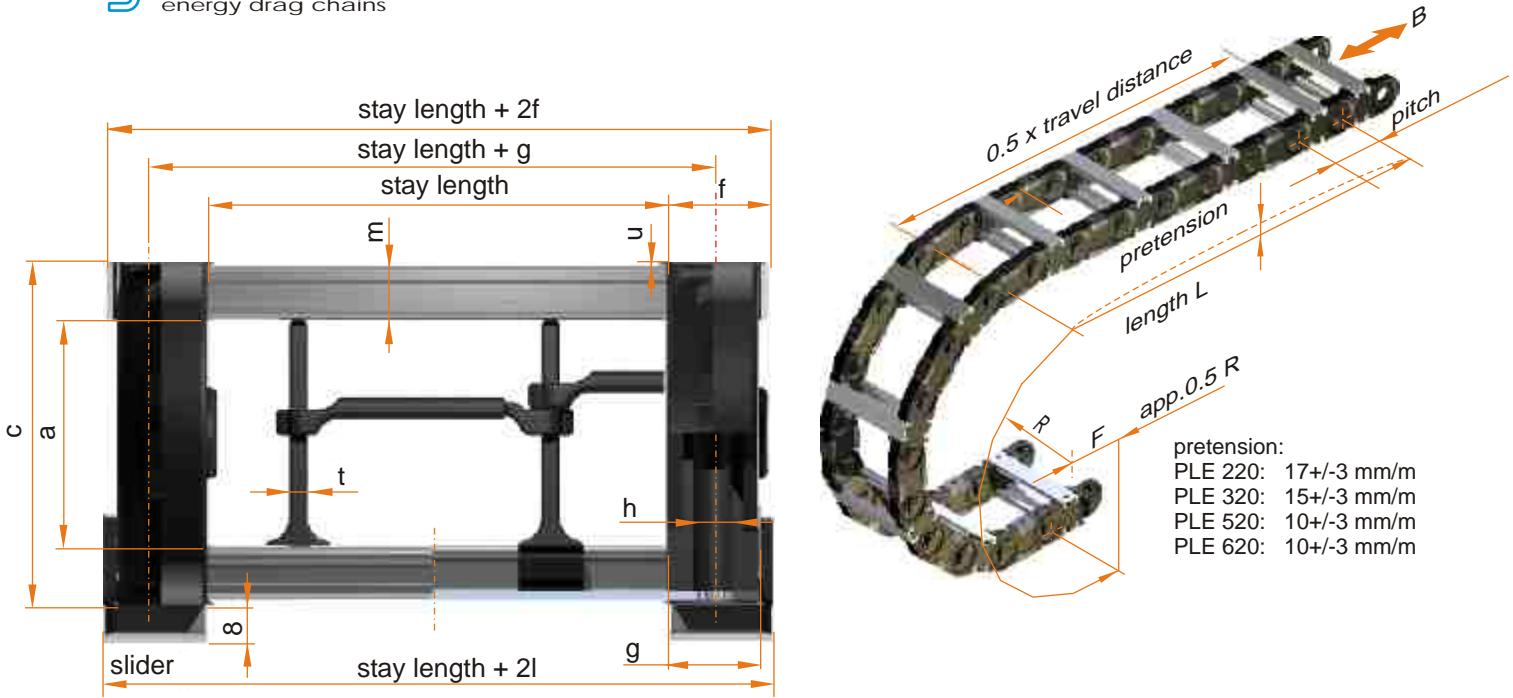

pretension:  
 PLE 220: 17+/-3 mm/m  
 PLE 320: 15+/-3 mm/m  
 PLE 520: 10+/-3 mm/m  
 PLE 620: 10+/-3 mm/m

The usable interior width is stay length - 2 mm

PLE	bending radius R [mm]	pitch	a	c	f	g	h	l <sup>1)</sup>	m	t	u	weight [kg/m] <sup>3)</sup>
220, 221	75 100 150 200 300	75	31	50	18	16	∅6	-	9	4	1	1.9
320, 321, 325, 328 <sup>2)</sup>	150 200 250 300 400	100	49	75	22	20	∅8	23	12	4	1	3.4 (4.4)
520, 521, 525, 528 <sup>2)</sup>	200 250 300 400 500	125	68	100	26	24	∅8	27	15	4	1	4.8 (5.9)
541, 548 <sup>2)</sup>	200 250 300 400 500	125	80	100	26	24	∅8	27	9	4	1	4.60
620, 621, 625 <sup>4)</sup>	230 300 400 500 700	187	115	150	32	32	∅10	-	15	8	2	7.20

1) stay length + 2l is the outside width, including sliders 2) PLE 328 from R200, PLE 528, 548 from R250  
 3) weight with stay length 100, values in brackets for closed version 4) 625 a = 120

The stay lengths are offered in steps of 1 mm.

PLE	minimum stay length [mm]	maximum stay length [mm]	PLE inserts ∅ [mm]																					
220, 221	50	800	10	15	20	25	30																	
320, 321, 325, 328	60	900	10	15	20	25	30	35	40	45	50													
520, 521, 525, 528	70	1000	10	15	20	25	30	35	40	45	50	55	60	65	70									
541, 548	70	900																						
620, 621, 625	90	1000																						

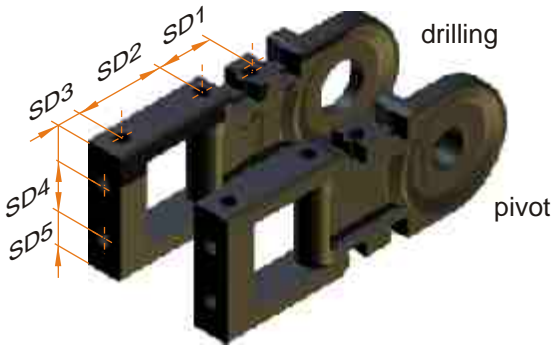

PLE SD- connector	SD1	SD2	SD3	SD4	SD5
220, 221, 225	22,5	37,5	8,5	22	7,5
320, 321, 325, 328	35	45	8,5	45	15
520, 521, 525, 528	35	45	8,5	66	17

order example: travel distance 3 m, bending radius 200 mm, cable: 1x15 mm, 8x8 mm, 3x12 mm, 2x22 mm, chain arrangement is hanging

PLE 320 / 200	x	2325	/ 200	/ SD 32, SD 32 /	h	/ 5 PZ, 1 Pt55
type / radius	x	length	/ stay length /	connectors /	arrangement /	stay distribution

PLE energy chains are distinguished from standard plastic chains by their extreme stability and the rigid, continuously adjustable aluminum profile. Stay lengths up to 1000 mm can be accommodated.

The allocation of the interior offers variable opportunities and guarantees optimum line protection even at high acceleration and travel speed.

The **PLE** (PLE with plastic inserts or plastic insert-profile) ensures a perfect guide at high speeds. Errors during installation of the cables are nearly impossible, with this variation, the hole design of the stays meet exactly the requirements of the lines. Plastic inserts are available in 5 mm steps. The plastic insert-profile can be ordered according to drawing.

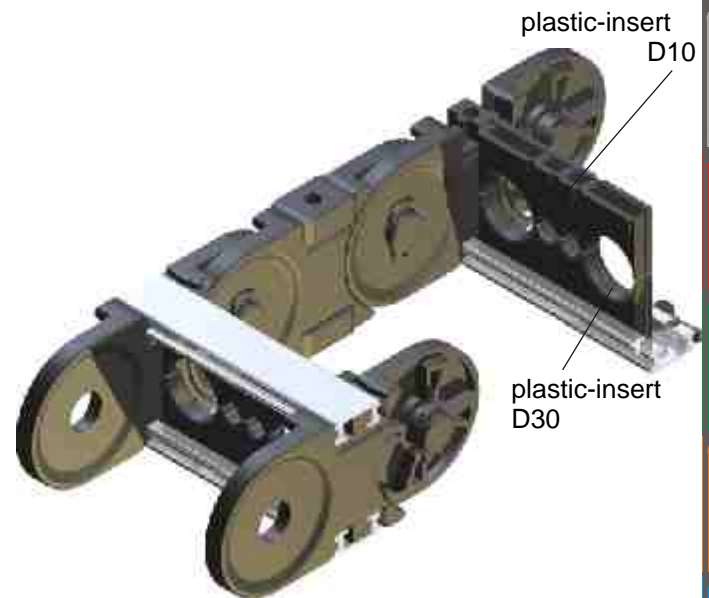

In case of limited installation space, the **PLS** (PLE with foam insert-profile) are used. Again, the optimal guiding of the lines at high speeds and acceleration is ensured. All lines are in the neutral axis (middle of chain height).

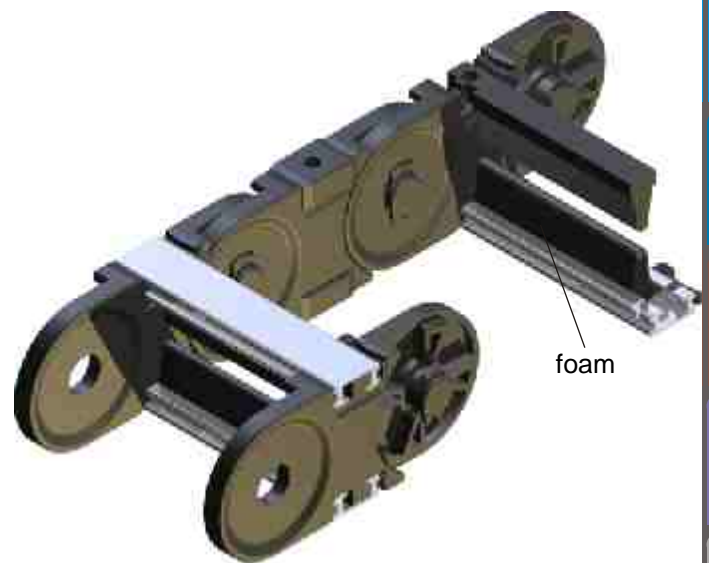

For space reasons the **PLP** (PLE with plastic dividers) may be chosen. This inexpensive design allows secure guiding of large amounts of cable. The highly variable stay distribution opportunities through the small steps (3mm) in height and the infinitely adjustable plastic telescopic dividers (PT) allow maximum space for all needs, even when changes in cable diameters are required.

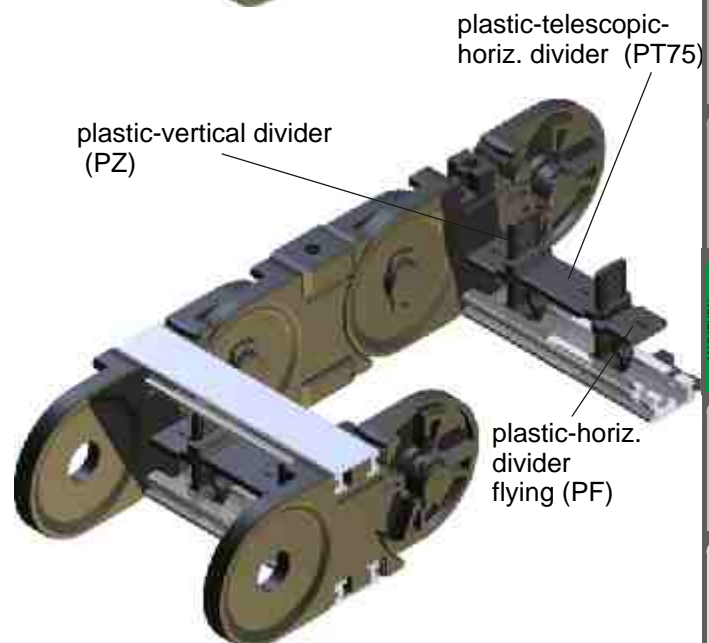

## PLE 220, 320, 520, 620

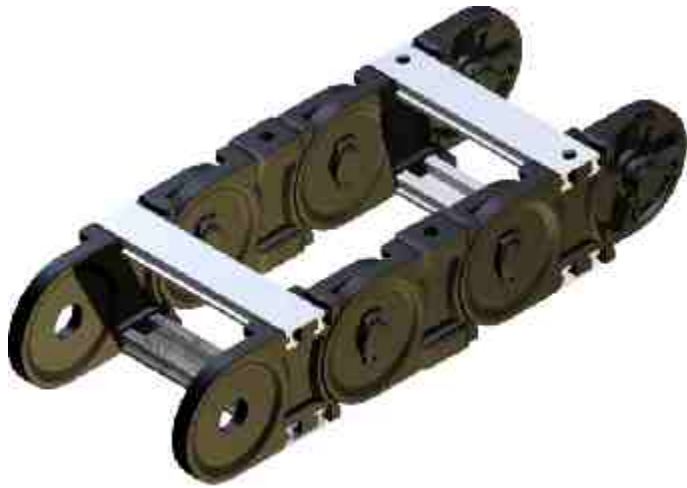

The standard type is build with stays in every second chain link. The **integrated connector** makes every link in the chain when needed to a connector (not 620) and therefore the separate ordering and storage of end connector brackets is not necessary.

order example:

<b>PLE 220</b>	/ 100	x 3525	/ 100
type	radius	length	stay length

## PLE 221, 321, 521, 541, 621

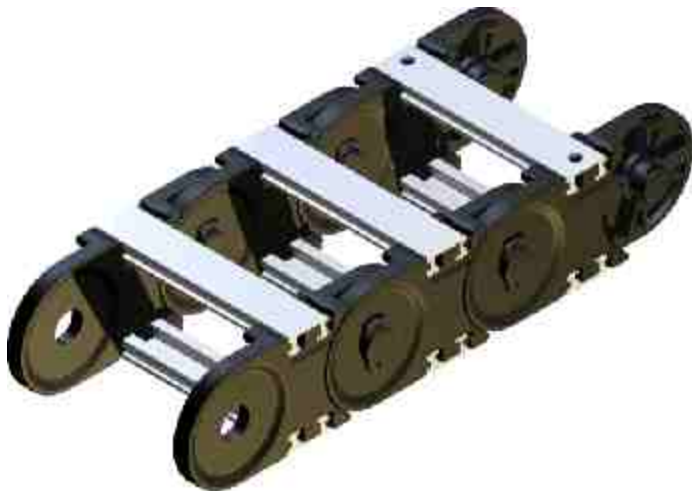

These designs are made with stays in each link. This increases the lateral stability and improves the guiding particularly of smaller diameter lines.

order example:

<b>PLE 221</b>	/ 100	x 3525	/ 100
type	radius	length	stay length

## PLE 325, 525, 625

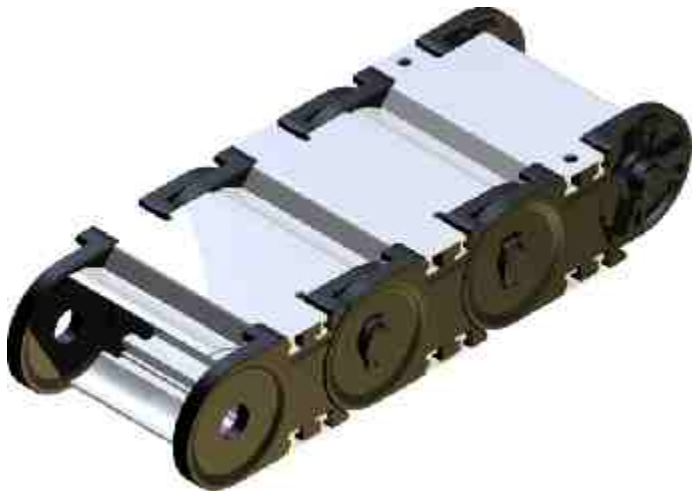

The closed types with aluminum covers may also replace the standard version stay. The covers can be opened in the inner or outer radius.

order example:

<b>PLE 325</b>	/ 300	x 3500	/ 100
type	radius	length	stay length

## PLE 328, 528, 548

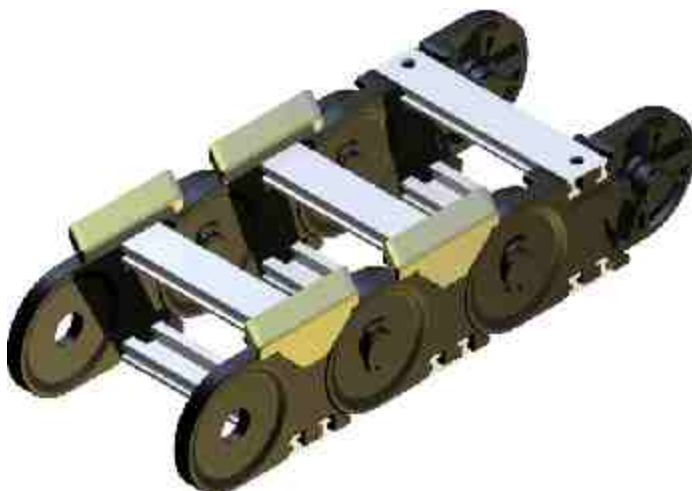

These types are suitable for long travel, the upper strand slides on the lower strand. For increased stability these energy chains are also build with stays in each link. The energy chains are fitted with sliders in the inner radius, which have a very low coefficient of friction ( $\mu = 0.2$  to  $0.25$ ). After reaching the wear limit, the slider can be renewed and the energy chain will continue. Subsequent slider assembly is also possible. Then, the stays must be provided with drilled location holes.

order example:

<b>PLE 328</b>	/ 200	x 3500	/ 100
type	radius	length	stay length

## PLE 220

standard type

height:	50	width:	86 ... 836
inner height:	31	inner width:	50 ... 800

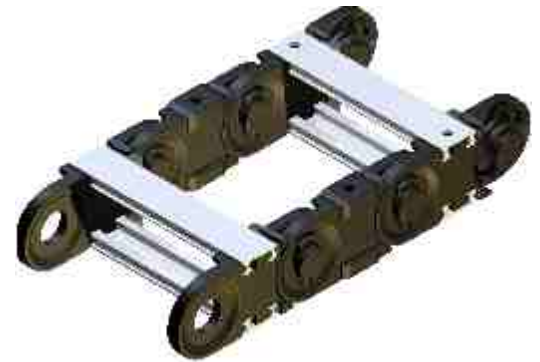

## PLE 320

standard type

height:	75	width:	104 ... 944
inner height:	49	inner width:	60 ... 900



## PLE 520

standard type

height:	100	width:	122 ... 1052
inner height:	68	inner width:	70 ... 1000

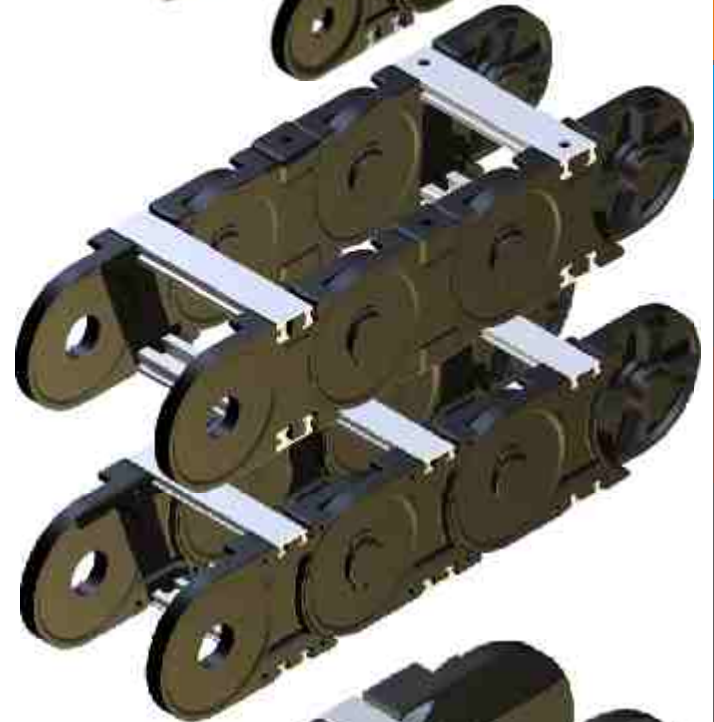

## PLE 541

stay in each link

height:	100	width:	122 ... 1052
inner height:	80	inner width:	70 ... 1000

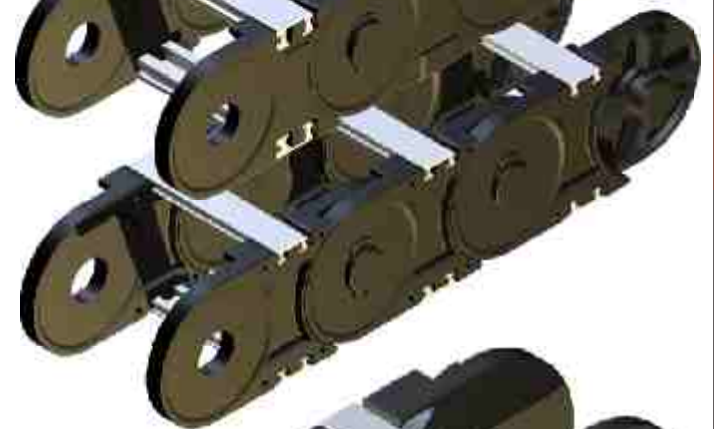

## PLE 620

standard type

height:	150	width:	154 ... 1064
inner height:	115	inner width:	90 ... 1000

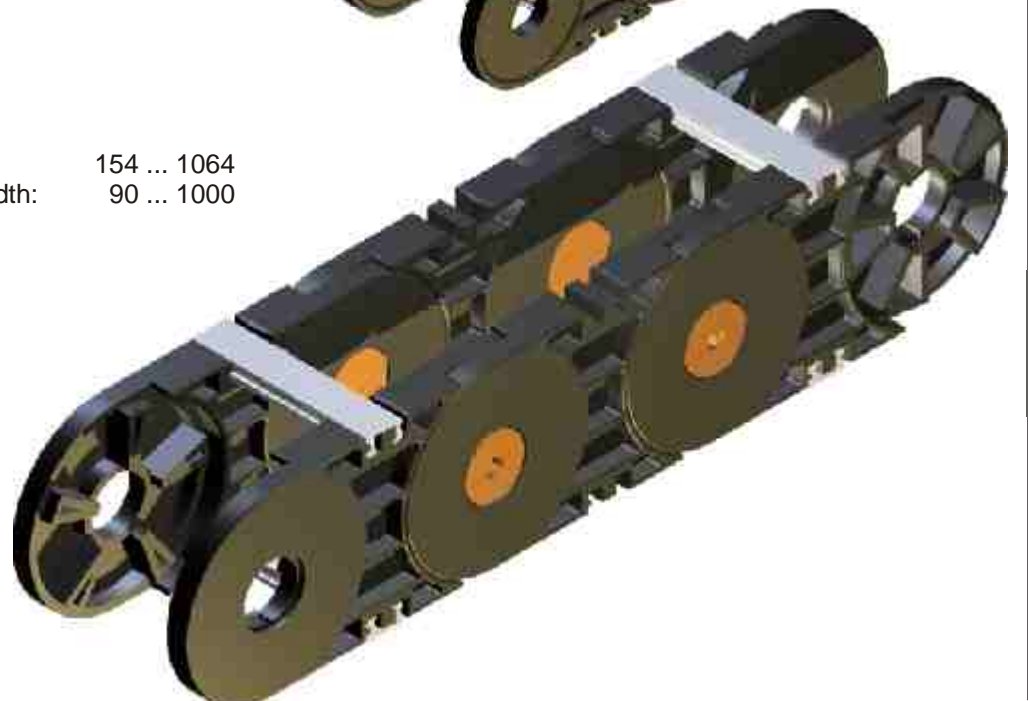

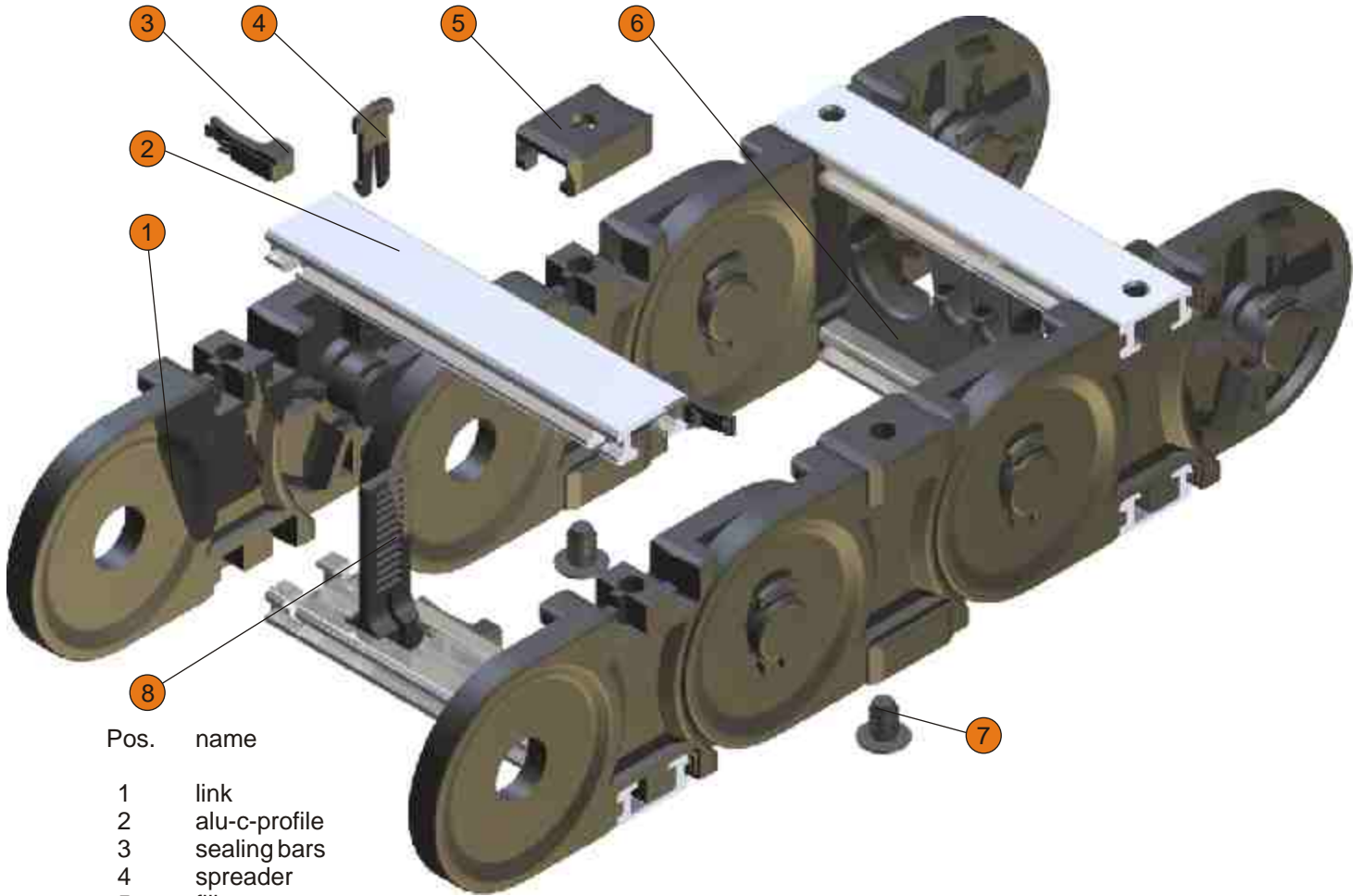

Pos.	name
1	link
2	alu-c-profile
3	sealing bars
4	spreader
5	filler
6	insert
7	damping element
8	plastic vertical divider (PZ)
9	inner cover
10	outer cover

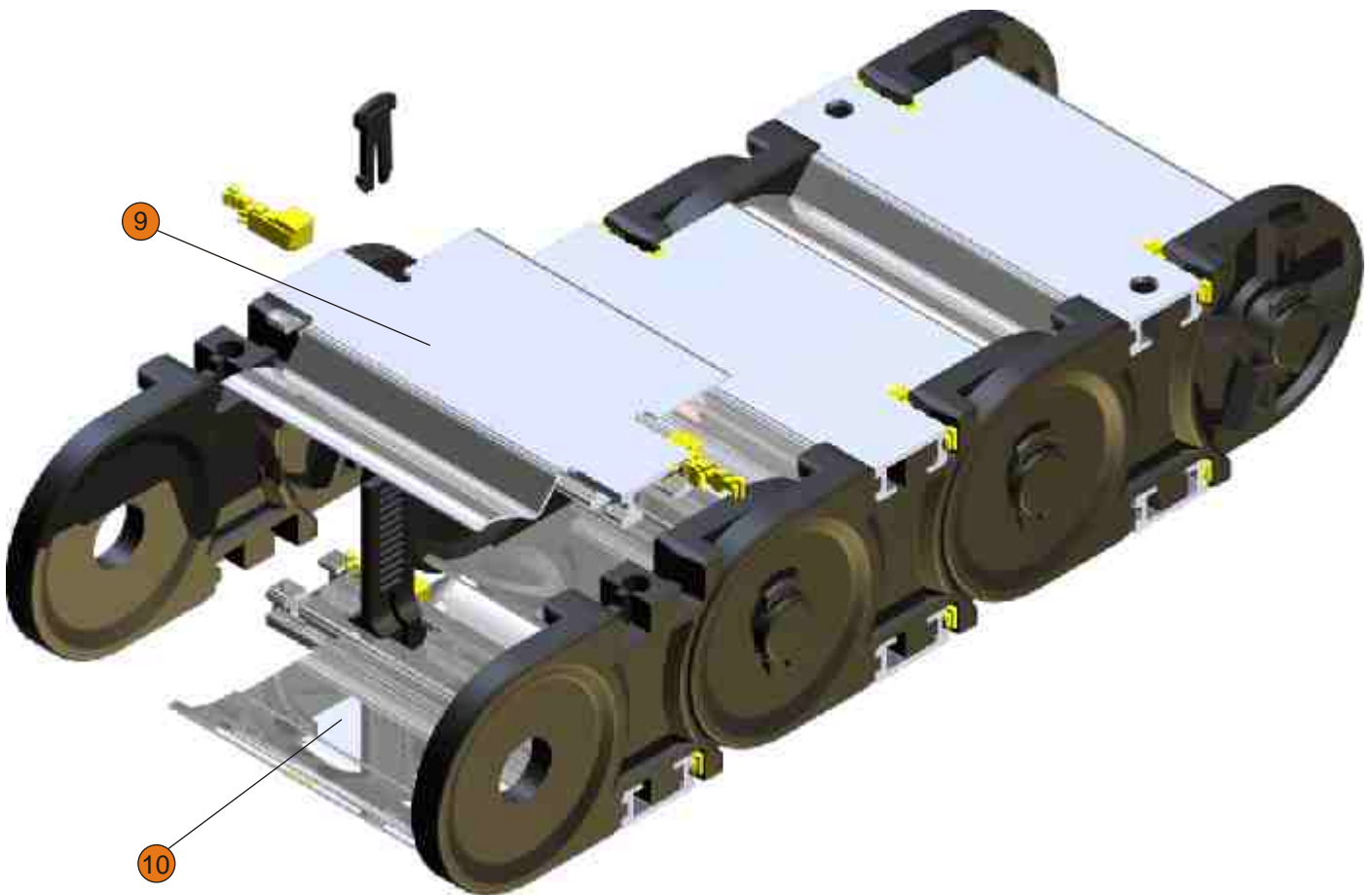

## Lengthening or shortening, link bands

To shorten the spreaders are disengaged (1), taken from (2,3) and the corresponding piece of chain removed (4). Lengthening is done by adding links and inter-lock with the spreaders.

Alternatively, first part of strands assembled or dismantled. Then a stay assembly or disassembly is required.

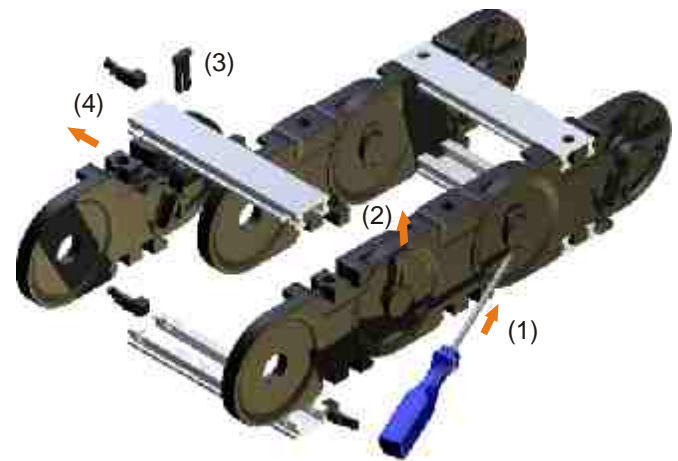

## Stay assembly

Stays are installed (1) and locked by horizontal shifting into place (2). Then pushing the sealing bars outside until they lock the link.

## Stay disassembly

Push sealing bar to the inside (4), unlock stay (5) and remove them (6).

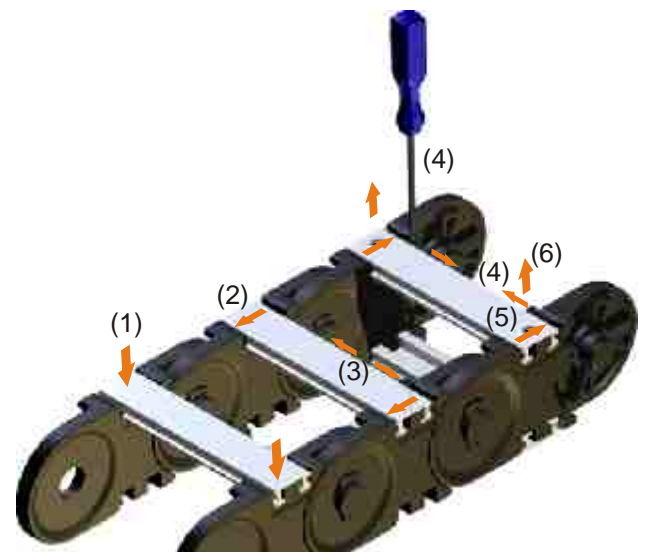

## Filler

The fillers are mounted in the recess and (possibly with a light plastic hammer) pushed until locked (1).

The dismantling of the fillers is done with a screwdriver. The screwdriver blade ought to be small enough to start behind the filler. Then unhinge the filler (2).

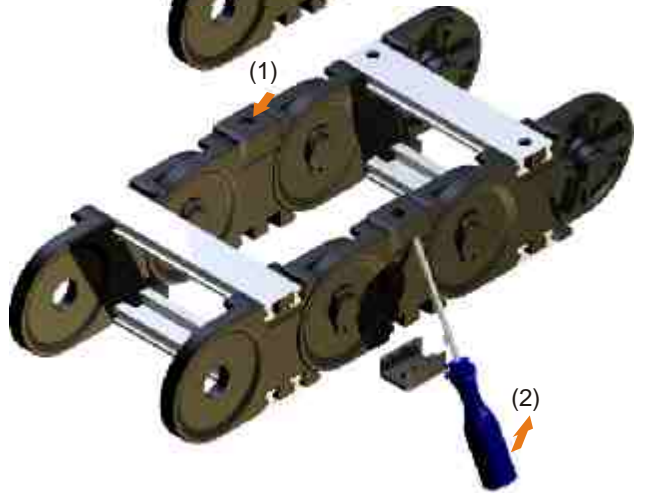

## Covers

The assembly of the covers is the same as the assembly and disassembly of the stays. The sealing bar is positioned in the designated position with a screwdriver.

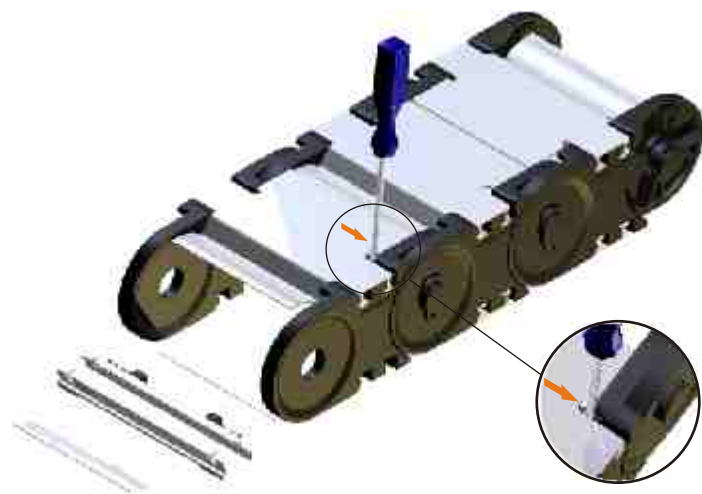



## Plastic inserts

The inserts are assembled according to the required lateral position (1) and inserted into the stay (2).

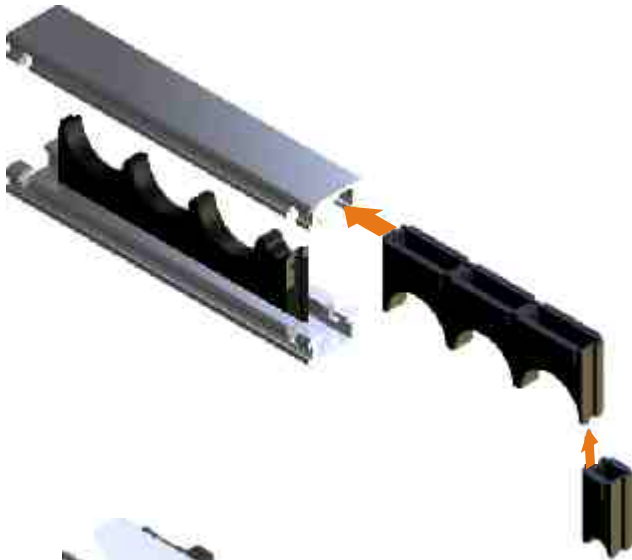

## Foam

The foam insert is pushed laterally into the aluminum-profile (1), before they are assembled to the chain links.



## Plastic divider PZ

The plastic dividers are hooked into the desired position with the long side of the foot in the aluminum bar and engaged with slight pressure (1).

Corrections of the position by lateral displacement are possible. The dismantling of the PZ is done by pulling in the opposite direction or sideways push out from the stay.

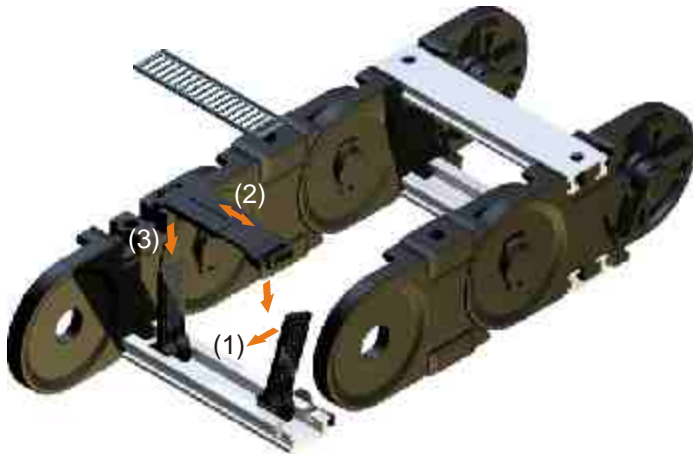

## Telescopic horizontal divider

The telescopic horizontal divider can be adjusted in length (2), vertically fitted on the PZ (3) and engaged in the designated height.

The dismantling is carried out with a screwdriver by unlocking and removal.

## Mounting the energy chain

All ekd plastic energy chains are equipped with **integrated connectors**. They allow the mounting of the energy chain with any link.

In gliding energy chain applications or for a smooth optical effect, the mounting holes in the fixed connector can be countersunk.

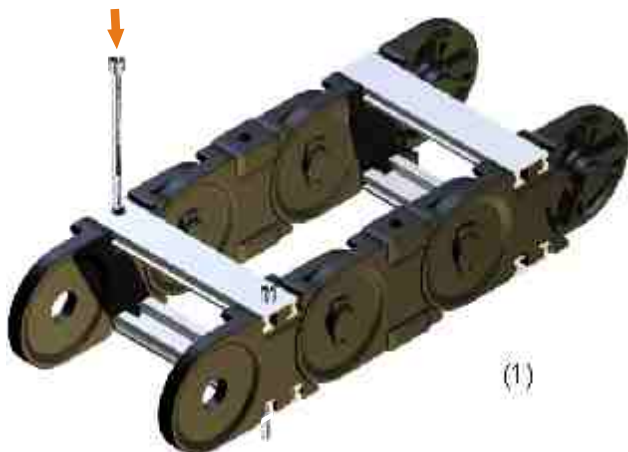

## Face mounting

The energy chain PLE can be optionally fitted with flange connectors. The flange connectors allow various mounting opportunities, mounted like chain links and secured with a stay.

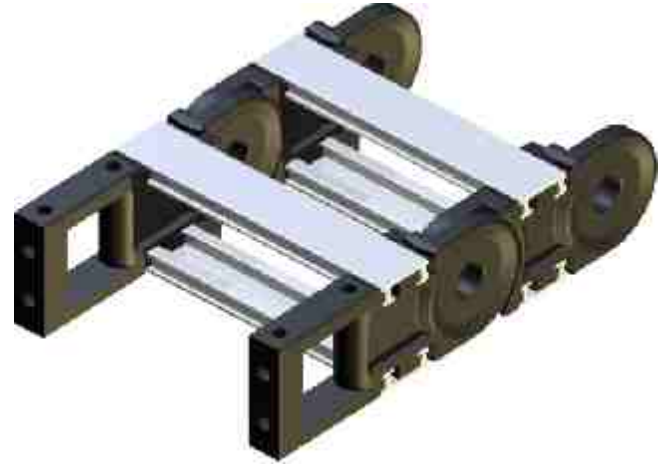

## Sliders

To avoid damage the slider must be conditioned (overnight storage in water at room temperature or 2 h at 80 °C).

The slider is positioned at the inner radius of the energy chain, with the pin in the bore of the stay (1) and pushed until the snap hook locks (2).

To dismantle unhinge the snap hook (3) and remove the slider to the top (4).

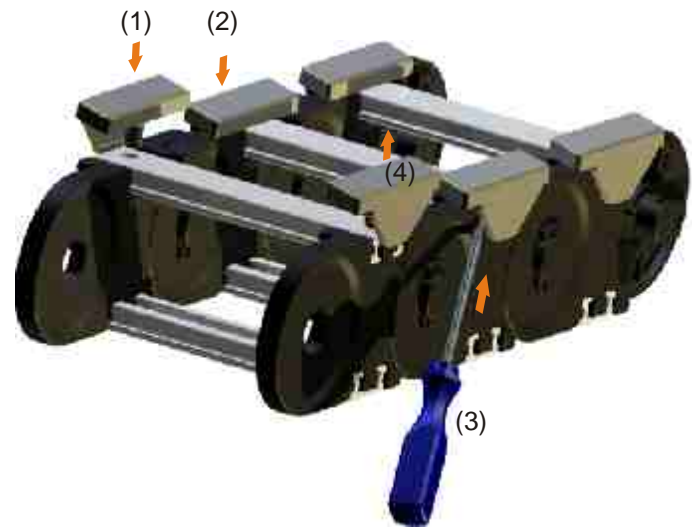

The implementation of an energy chain with sliders has to be done smoothly. In addition, the glide bars (1) should be fitted with contour at the end of the energy chain and counter sinking the connector screws (2). The distance between the glide bar to the first slider should be less than the slider length (3).

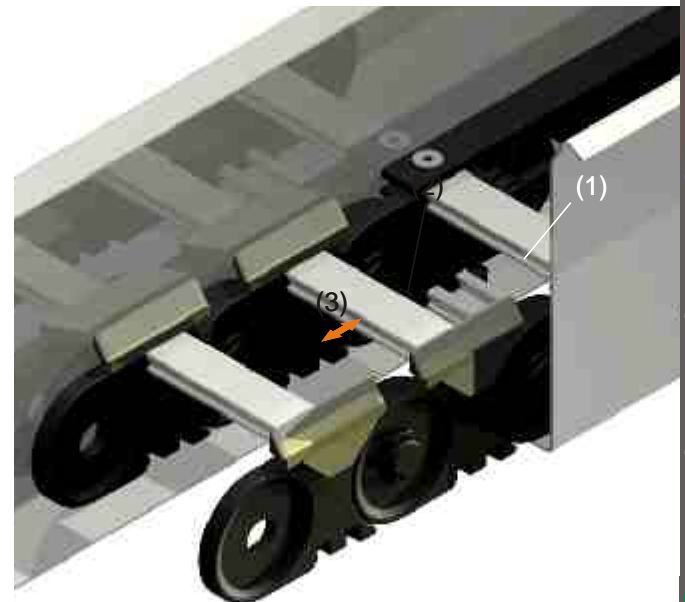

## Maintenance of the energy chain

PLE energy chains are maintenance free. Like every mechanical system this will depend on the ambient conditions so wear will occur which must be observed.

In case of the energy chain has to be replaced.

For long travels or in a circular motion, the energy chains are often equipped with sliding elements. These allow sliding of the upper part of the chain on a suitable surface (eg, slider-slider, slider-steel, glide bar).

The sliders wear depends on the application. The slider surfaces should be checked at regular intervals. With a thickness of 1-2 mm sliders have to be replaced.

PLE parts 72

special material parts like UI94 V-0, EX or other have to be named in the order



1

PLE	link					
	<b>R</b>	<b>75</b>	<b>100</b>	<b>150</b>	<b>200</b>	<b>300</b>
<b>220</b>	m.V.	0346	1190	1219	1191	1192
	o.V.	1193	1194	1218	1195	1196
<b>221</b>	m.V.	0346	1190	1219	1191	1192
	o.V.	1193	1194	1218	1195	1196
	<b>R</b>	<b>150</b>	<b>200</b>	<b>250</b>	<b>300</b>	<b>400</b>
<b>320</b>	m.V.	0351	1197	1198	1199	1200
	o.V.	1201	1202	1203	1204	1205
<b>321</b>	m.V.	0351	1197	1198	1199	1200
	o.V.	1201	1202	1203	1204	1205
<b>325</b>	m.V.	0351	1197	1198	1199	1200
	o.V.	1201	1202	1203	1204	1205
<b>328</b>	m.V.	-	1197	1198	1199	1200
	o.V.	-	1202	1203	1204	1205
	<b>R</b>	<b>200</b>	<b>250</b>	<b>300</b>	<b>400</b>	<b>500</b>
<b>520</b>	m.V.	0944	1206	1207	1208	1209
	o.V.	1211	1212	1213	1214	1215
<b>521</b>	m.V.	0944	1206	1207	1208	1209
	o.V.	1211	1212	1213	1214	1215
<b>525</b>	m.V.	0944	1206	1207	1208	1209
	o.V.	1211	1212	1213	1214	1215
<b>528</b>	m.V.	-	1206	1207	1208	1209
	o.V.	-	1212	1213	1214	1215
	<b>R</b>	<b>200</b>	<b>250</b>	<b>300</b>	<b>400</b>	<b>500</b>
<b>541</b>	m.V.	1611	1607	1608	1609	1610
	o.V.	-	-	-	-	-
<b>548</b>	m.V.	1611	1607	1608	1609	1610
	o.V.	-	-	-	-	-
	<b>R</b>	<b>230</b>	<b>300</b>	<b>400</b>	<b>500</b>	<b>700</b>
<b>620</b>	m.V.	1104	1100	1101	1102	1103
	o.V.	-	-	-	-	-
<b>621</b>	m.V.	1104	1100	1101	1102	1103
	o.V.	-	-	-	-	-
<b>625</b>	m.V.	2029	2153	2154	2155	2156
	o.V.	-	-	-	-	-

# PLE PART NUMBERS

4



5



7



2



3



10

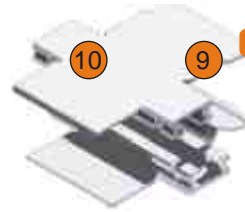

9



PLE parts

72

PLE

SR

PS

FK

C-profile

SRR/SRR5

ASA

ASI

foam

220	0348	0345	1269	0976	0344		-	-	0730
221	0348	-	1269	0976	0344		-	-	0730

320	0353	0350	1317	0977	0349		-	-	0731
321	0353	-	1317	0977	0349		-	-	0731
325	0353	-	1317	-	1668 1669		1640	1638	0731
328	0353	-	1317	0977	0349		-	-	0731

520	0358	0943	1317	0978	0942		-	-	0732
521	0358	-	1317	0978	0942		-	-	0732
525	0358	-	1317	-	1656 1657		1641	1639	0732
528	0358	-	1317	0978	0942		-	-	0732

541	0358	-	1317	0976	1676		-	-	-
548	0358	-	1317	0976	1676		-	-	-

hub



connector angle

left right  
1630 1629



cover connector angle



620	1109	-	-	0978	1328				1631
621	1109	-	-	0978	1328				1631
625	1109	-	-		1961		1986	1985	1631

PLE parts 72

8



PLE	PZ	PTF	PT 55	PT 75	LL 25	LL 50	LS	GL	ZL	ZLA8	ZLS10	ZHS10	SDA Drilling Pin
-----	----	-----	-------	-------	-------	-------	----	----	----	------	-------	-------	---------------------

220	0778	1519	1927	0879	0880	1663	1664	1421	-	1273	1159	1160	1407	1439 1761
221	0778	1519	1927	0879	0880	1663	1664	1421	-	1273	1159	1160	1407	1439 1761



320	0163	1678	1927	0879	0880	1663	1664	1421	-	1273	1159	1160	1407	1773 1774
321	0163	1678	1927	0879	0880	1663	1664	1421	-	1273	1159	1160	1407	1773 1774
325	0163	1678	1927	0879	0880	1663	1664	1421	1450	1273	1159	1160	1407	1773 1774
328	0163	1678	1927	0879	0880	1663	1664	1421	1450	1273	1159	1160	1407	1773 1774



520	0719	1680	1927	0879	0880	1663	1664	1421	-	1675	1159	1160	1407	1775 1776
521	0719	1680	1927	0879	0880	1663	1664	1421	-	1675	1159	1160	1407	1775 1776
525	0719	1680	1927	0879	0880	1663	1664	1421	1449	1675	1159	1160	1407	1775 1776
528	0719	1680	1927	0879	0880	1663	1664	1421	1449	1675	1159	1160	1407	1775 1776



541	1613		1927	0879	0880	1663	1664	1421	-	1675	1159	1160	1407	
-----	------	--	------	------	------	------	------	------	---	------	------	------	------	--

548	1613		1927	0879	0880	1663	1664	1421	1449	1675	1159	1160	1407	
-----	------	--	------	------	------	------	------	------	------	------	------	------	------	--



620	1110	1933	-	-	-	-	-	-	-	1612	1159	1160	1407	
-----	------	------	---	---	---	---	---	---	---	------	------	------	------	--

621	1110	1933	-	-	-	-	-	-	-	1612	1159	1160	1407	
-----	------	------	---	---	---	---	---	---	---	------	------	------	------	--

625			1980	-	-	-	-	-	-	1612	1159	1160	1407	
-----	--	--	------	---	---	---	---	---	---	------	------	------	------	--

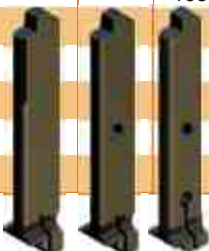

# PLE PART NUMBERS

## inserts

special material parts like UI94 V-0, EX or other have to be named in the order

6

diameter in mm



PLE 10 15 20 25 30 35 40 45 50 55 60 65 70



220	0649	0650	0651	0652	0653	-	-	-	-	-	-	-	-
221	0649	0650	0651	0652	0653	-	-	-	-	-	-	-	-

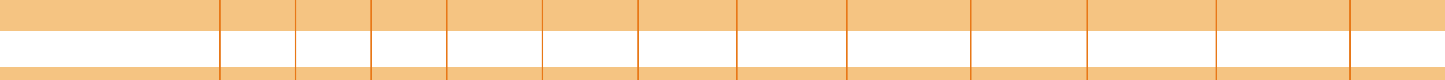

320	0654	0665	0656	0657	0658	0659	0660	0661	0662	-	-	-	-
321	0654	0665	0656	0657	0658	0659	0660	0661	0662	-	-	-	-
325	0654	0665	0656	0657	0658	0659	0660	0661	0662	-	-	-	-
328	0654	0665	0656	0657	0658	0659	0660	0661	0662	-	-	-	-



520	1628	0663	0664	0665	0666	0667	0668	0669	0670	0671	0672	0714	0715
521	1628	0663	0664	0665	0666	0667	0668	0669	0670	0671	0672	0714	0715
525	1628	0663	0664	0665	0666	0667	0668	0669	0670	0671	0672	0714	0715
528	1628	0663	0664	0665	0666	0667	0668	0669	0670	0671	0672	0714	0715



541	-	-	-	-	-	-	-	-	-	-	-	-	-
548	-	-	-	-	-	-	-	-	-	-	-	-	-



620	-	-	-	-	-	-	-	-	-	-	-	-	-
621	-	-	-	-	-	-	-	-	-	-	-	-	-
625	-	-	-	-	-	-	-	-	-	-	-	-	-

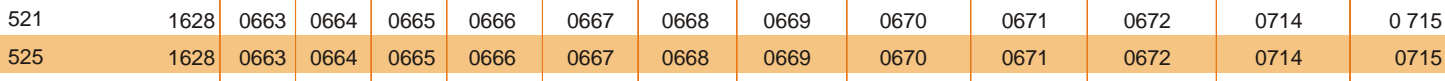

620	-	-	-	-	-	-	-	-	-	-	-	-	-
621	-	-	-	-	-	-	-	-	-	-	-	-	-
625	-	-	-	-	-	-	-	-	-	-	-	-	-



620	-	-	-	-	-	-	-	-	-	-	-	-	-
621	-	-	-	-	-	-	-	-	-	-	-	-	-
625	-	-	-	-	-	-	-	-	-	-	-	-	-



620	-	-	-	-	-	-	-	-	-	-	-	-	-
621	-	-	-	-	-	-	-	-	-	-	-	-	-
625	-	-	-	-	-	-	-	-	-	-	-	-	-



620	-	-	-	-	-	-	-	-	-	-	-	-	-
621	-	-	-	-	-	-	-	-	-	-	-	-	-
625	-	-	-	-	-	-	-	-	-	-	-	-	-

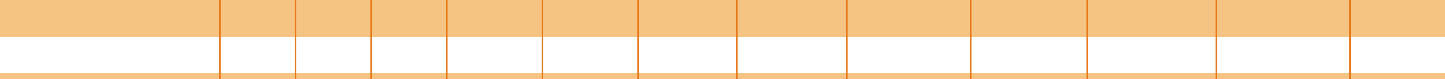

620	-	-	-	-	-	-	-	-	-	-	-	-	-
621	-	-	-	-	-	-	-	-	-	-	-	-	-
625	-	-	-	-	-	-	-	-	-	-	-	-	-

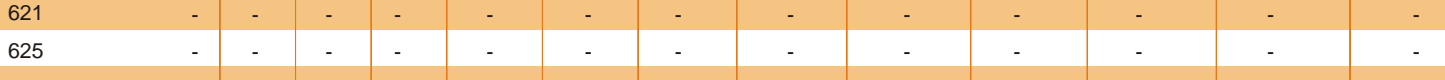

620	-	-	-	-	-	-	-	-	-	-	-	-	-
621	-	-	-	-	-	-	-	-	-	-	-	-	-
625	-	-	-	-	-	-	-	-	-	-	-	-	-

